

Differences in FM18L08 and FM28V020

Applies to 256Kb Parallel F-RAM Devices



DESCRIPTION

This document points out the differences the FM18L08 and FM28V020 parallel F-RAM devices. For most designs, the FM28V020 device can be considered equivalent or better than the FM18L08. The two devices are identical in terms of pinout, package dimensions and composition, and read/write functionality. In terms of speed, the FM28V020 has faster access timing and cycle timing. The FM28V020 also incorporates a page-mode feature that allows read/write operations up to 33MHz.

DROP-IN REPLACEMENT OR NOT

From a software point of view, the two devices are identical. From a hardware point of view, the key difference between the two devices is the FM28V020's higher standby current. The FM28V020 adds many features: operates down to 2.0V, page-mode operation, and higher speed capability. The page mode feature could present an issue in systems that change the address in the middle of an access. See timing example on the next page. The summary table below highlights the differences.

COMPATIBILITY CHART

FM18L08 Feature or Spec	... is FM28V020 compatible?
Package	Yes
Pinout	Yes
Temperature Range	Yes
Operating Voltage	Yes
Operating Current	Yes
Standby Current	No
R/W Function	Yes
Timing/Freq	Yes*
Data Retention	Yes †
Endurance	Yes †

* Assumes the address is held throughout cycle and /OE not in the critical path.

† See table on next page.

DETAILED COMPARISON TABLE

Differences are highlighted in yellow.

	FM18L08	FM28V020	Comments
Package Types	-SG, PG, -TG	-SG, -TG	SOIC and TSOP supported
Package Outlines	28-pin SOIC, DIP 32-pin TSOP	28-pin SOIC 32-pin TSOP	Same SOIC and TSOP outline and board footprint
Pinout	-	-	Same
Temperature Range	-40C to +85C	-40C to +85C	Same
Operating Voltage Range	3.0 to 3.6V	2.0 to 3.6V	FM28V020 allows operation down to 2V
Active Supply Current	15mA @ 140ns cycle	12mA @ 90ns cycle	The 28V020 offers lower active current.
Standby Current	15µA	150µA	FM28V020 has higher I _{SB} .
Read/Write Function	-	-	Same R/W function, same addressing
Access Time	70 ns	60 ns	FM28V020 is faster
Cycle Time	140 ns	90 ns	FM28V020 is faster
t_{AH} Address Hold Time	15 ns	60 ns	FM28V020 requires a longer address hold time to avoid page mode access. Most systems will hold the address stable throughout the entire cycle but this is a timing parameter to check.
t_{OE} Output Enable Access Time	10 ns	15 ns	Most system designs, the /OE pin is not in the critical path but this is a parameter to check.
Data Retention	45 yrs (+85°C)	38 yrs (+75°C)	Nearly the same
Endurance	Unlimited	1E+14	FM28V020 is unlimited at 200ns cycle time (182 yrs for a 256-byte loop)

OTHER			
V_{DD} Rise/Fall Time	-	50µs/V, 100µs/V	New power supply restrictions
t_{PU} Power Up Time	1 µs	250 µs	FM28V020 slower to first access
/CE low time max.	2000 ns	-	FM28V020 has no restrictions
/CE pulsed every access	Yes	-	FM28V020 does not require this, however the device will respond to address changes while /CE is low which is different behavior.
Page Mode Access	-	Yes	FM28V020 in-page accesses up to 33MHz

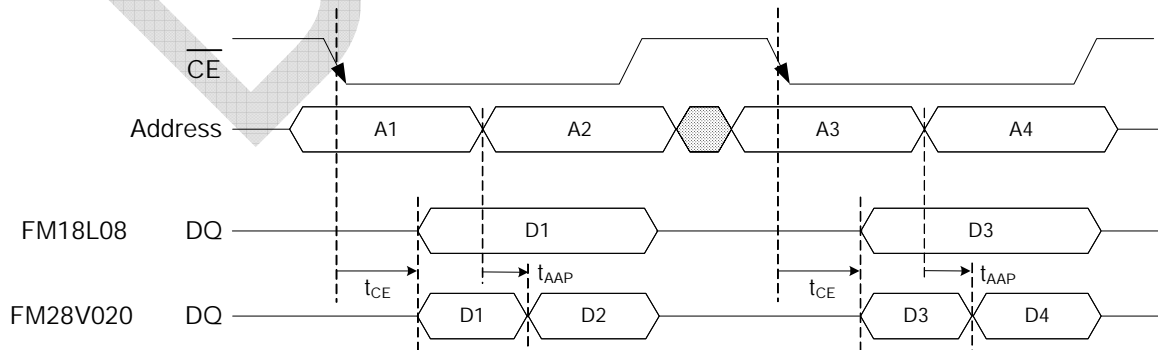

Difference in Response to Address Change (Read Cycle)