

Carrier Tape Critical Dimensions

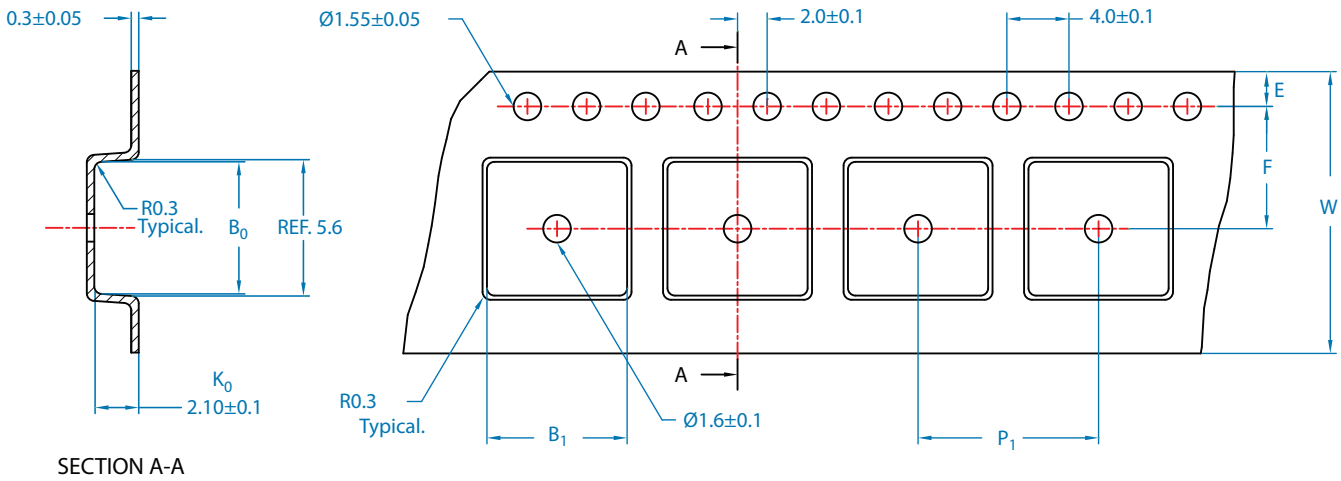

Lead Count	Package	Carrier Tape Dimensions (mm)							
		W	F	E	B <sub>0</sub>	B <sub>1</sub>	K <sub>0</sub>	Pitch (P <sub>1</sub> )	Thickness
8	EIAJ 8-pin	16.00 ± 0.3	7.50 ± 0.1	1.75 ± 0.1	5.70 ± 0.1	8.30 ± 0.1	2.30 ± 0.1	12.00 ± 0.1	0.30 ± 0.05

Cover Tape Width	Reel Diameter	Leader Length	Trailer Length	Qty / Reel
13.3 mm	329.2 mm	390 mm	160 mm	2000

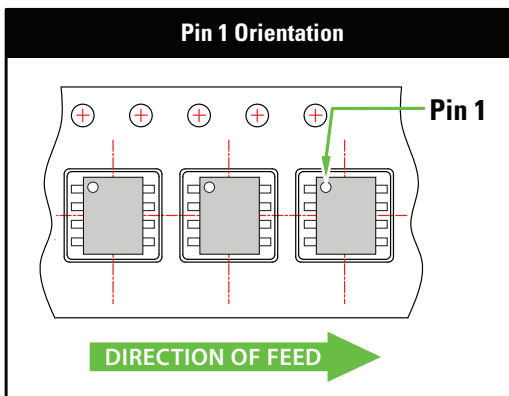

**Typical Label Specifications**

- Product number
- Lot number (max. 2 lots)
- Quantity (of ea. lot)
- Internal mfg. no. (optional)
- Country of origin
- Date code
- No. of boxes in shipment
- Quality assurance stamp

## Plastic Reel Dimensions

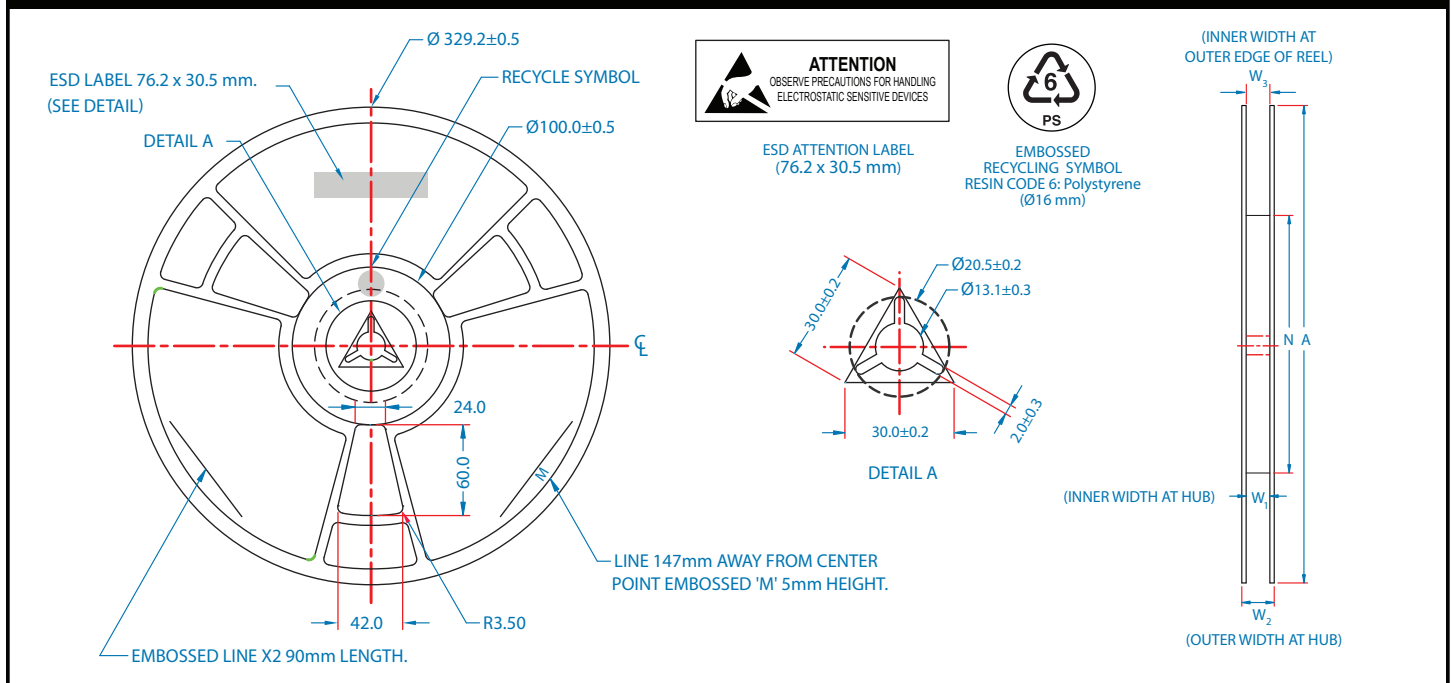

A (mm)	N (mm)	$W_1$ (mm)	$W_2$ (mm)	$W_3$ (mm)	B (mm)	C (mm)	D (mm)
$329.2 \pm 0.5$ (13")	$100 \pm 0.5$	$17.4 \pm 0.1$	22.4	15.9 - 22.4	$2.0 \pm 0.3$	$13.1 \pm 0.3$	$20.5 \pm 0.2$

## Cover Tape Dimensions

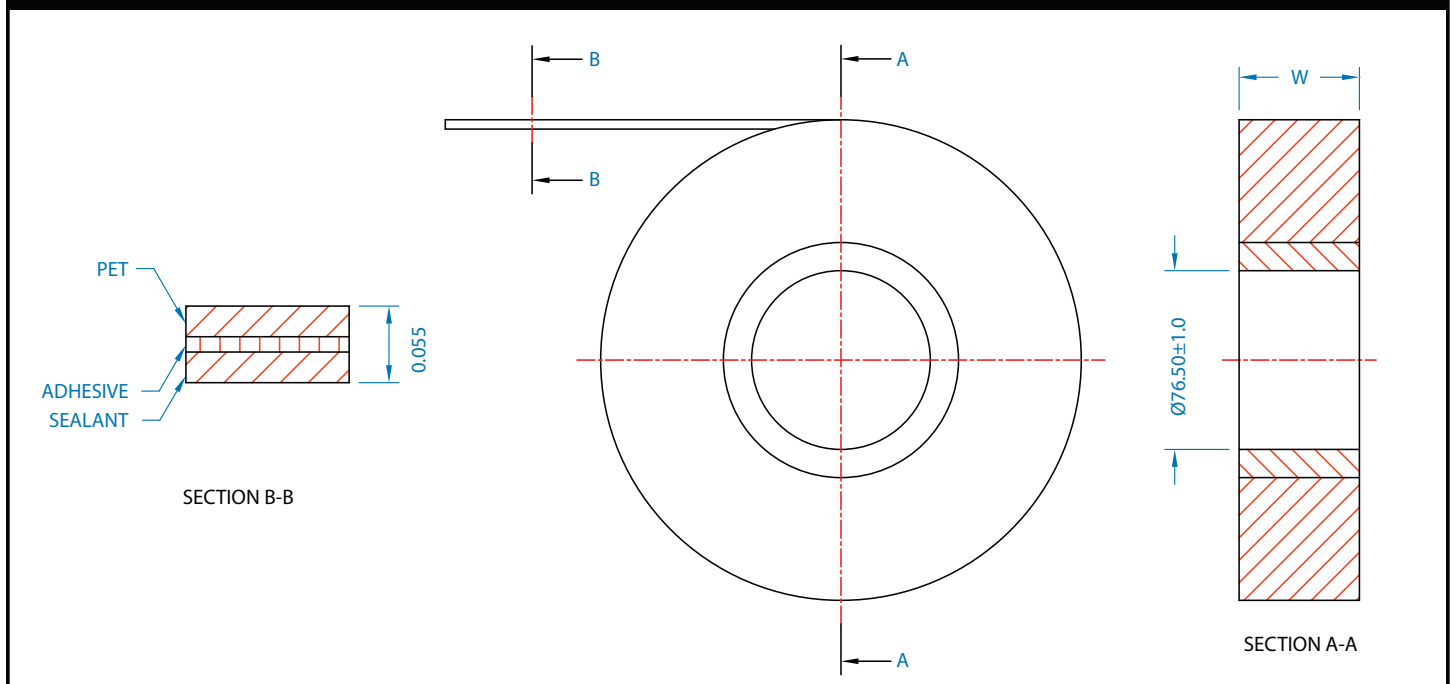

Cover Tape Width (W)	Cover Tape Thickness
$13.3 \pm 0.1 \text{ mm}$	$0.045 \pm 0.065 \text{ mm}$